

Designed
in the USA

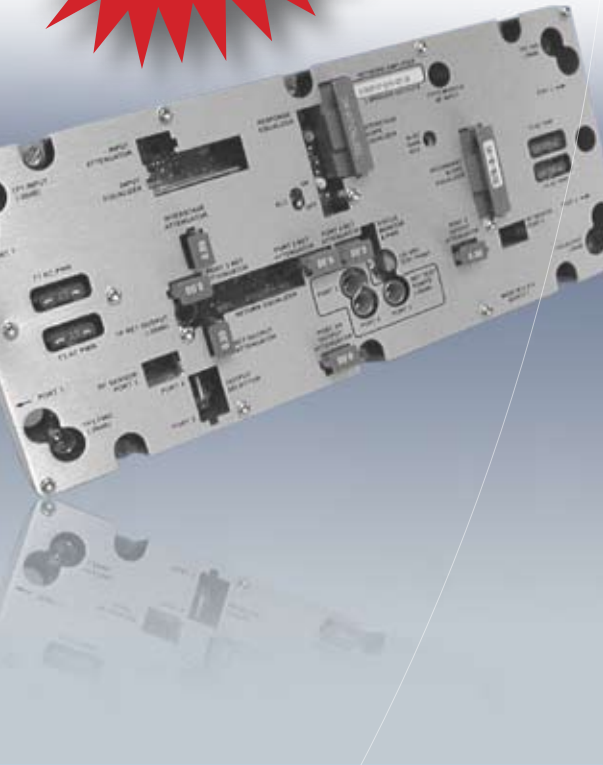

Bridger Amplifier

G4A HO GaAs

The Diamond Line II G4A* High Output (HO GaAs) amplifier series is an industry standard for RF distribution products. Offering GaAs technology, these amplifiers let you efficiently extend your network using the same legacy plug-ins as the GNA and G3A style amplifiers. The Diamond Line II G4A HO GaAs amplifiers also support the drop-in upgrade to RF cascades using an installed base of 9-NH series housings. In addition, two high output GaAs hybrids provide higher output levels and enhanced distortion performance.

Integrated return path circuitry uses the latest in GaAs hybrid technology with an improved compression point and bit error rate (BER) for digital-loaded traffic over a discrete amplifier design. Manual level control units are available to accommodate your design and budget.

Diamond Line II G4A HO GaAs bridger amplifiers provide two equal or three unequal high-level RF distribution outputs. A plug-in output port selector lets you choose either or both secondary outputs.

MAIN FEATURES:

- Suitable drop-in module upgrade to GNA 9-NH housings.
- Modules typically achieve 65dB hum modulation while continuously passing 15 amps.
- Plug-in equalisers and attenuators come with guides that simplify installation and plastic covers that protect components.
- Design offers excellent return-path performance.
- Optimal response equalisers provide forward path signal correction in amplifier cascades.
- Available in 42/54MHz and 65/85MHz versions.

Functional Block Diagram

Two output hybrids: one main output interstage amplifier and one for secondary output.

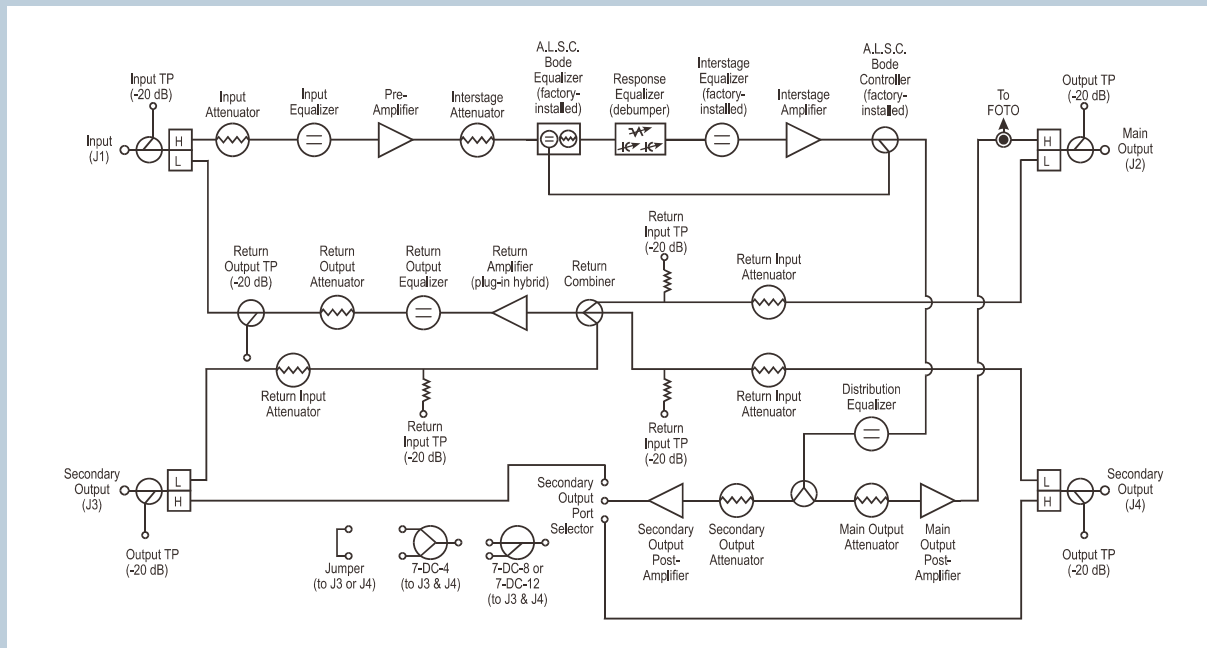

Diamond Line II Plug-In Circuits

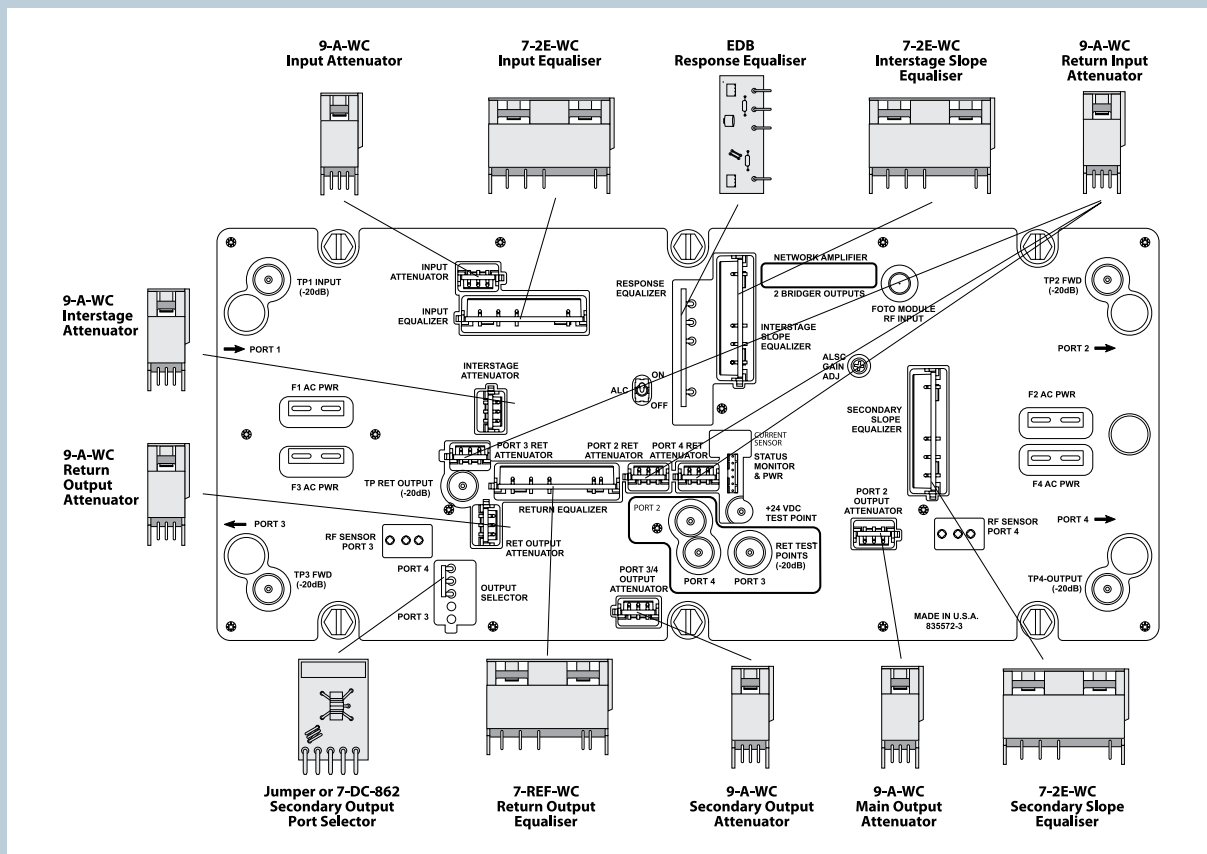

Note: Diamond Line II amplifiers are shipped with a jumper in the secondary output port selector position, allowing you to use either of the secondary output ports: J3 or J4. To use both secondary output ports, order the appropriate 7-DC series plug-in.

Diamond Line II G4A HO GaAs Bridger Amplifier Specifications

	Forward Bridger (ea)	Return Bridger (ea)	Forward Bridger (ea)	Return Bridger (ea)
General				
Pass Band, MHz	54 - 870	5 – 42	85 - 870	5 – 65
AC Current Passing, A	15	15	15	15
Typical Operating Conditions				
Operational Gain, dB (Note 1)	40	16	40	16
Channels, Number of NTSC (Note 2)	112/96/79	6	112/96/79	6
Operating Levels (recommended)				
Frequency, MHz	870/750/650/550/54	42/5	870/750/650/550/85	65/5
Input, dBmV, min. (Note 3)	12/11.5/11/11/11.5	19/19	11/11	19/19
Output, dBmV	52/50.2/48.6/47.1/39.5	35/35	52/44	35/35
Performance Specifications @ Specified Levels - Temperature Range: -40 to 60°C				
Carrier-to-Interference Ratio, dB (Note 4)				
Composite Triple Beat	62/67/72	86	73	82
Cross Modulation (per NCTA std.)	60/64/70	76	66	74
Composite 2IM	70/72/76	79	71	86
Composite Intermodulation Noise (CIN) (Note 5)				
Noise, 4MHz, 75Ohms	62.5/62/61.5/61.5/62	67	58.8	68
Noise Figure, dB (without EQ)	7.5/7.5/7.5/7.5/7.5	10	8.5	10
Factory Alignment (with ALC Reserve, without EQ)				
Cable Loss, dB @ 870MHz	16.5	-	16.5	-
Flatness, ±dB	0.75	0.5	0.75	0.5
Return Loss, dB min., all entry ports	15	16	15	16
Powering Requirements				
AC Power Consumption (worst case @ 1.73 ADC), Watts	47	47	47	47
Level Control				
Range, dB @ 870MHz	±3.0dB	-	±3.0dB	-
Accuracy (-40 to 60°C)	±1.0dB	-	±1.0dB	-
Output Level Range (from nominal)	+4/-2dB	-	+4/-2dB	-
Operating Ambient Temperature, °C	-40 to 60	-	-40 to 60	-
Module Dimensions, W x H x D cm	32.5 x 14.2 x 9.1	-	32.5 x 14.2 x 9.1	-
Module Weight, kg	2.0	-	2.0	-

ARRIS Specification Document Number 2244001 Rev F

- Includes 1dB input EQ losses
 - NTSC video channels occupying the appropriate frequency spectrum per specified number of channels.
 - Recommended minimum forward input level at 870MHz including loss due to equalizer.
 - Distortion performance is derated accordingly to take into account the influence of the digitally compressed channels operating 6dB below equivalent video channels.
 - Systems operating with digitally compressed channels or equivalent broadband noise from 550-870MHz at levels 6dB below equivalent video channels will experience a composite distortion (CIN) appearing as noise in the 54-550MHz / 85-550MHz frequency spectrum.
- Specifications are subject to change without notice.

PLUG-IN CIRCUITS

Factory-Installed Plug-Ins - Circuits or jumpers are installed in these positions for optimum performance according to customer or product requirements. (Factory-installed plug-ins are shown in plug-in diagrams only if users may change them.)

7-2E-WC Interstage Slope Equalizer

Required Plug-Ins - These positions are shipped empty. Select and install the appropriate value based on network design.

9-A-WC/10-A-WC Input Attenuator
 7-2E-WC Input Equaliser
 7-REF-WC Return Output Equaliser
 9-A-WC/10-A-WC Return Output Attenuator

Optional Plug-Ins - Replace these jumpers, or "zero" value circuits, shipped in these positions based on system design and performance

9-A-WC/10-A-WC Interstage Attenuator
 EDB Response Equaliser (debumper)
 7-2E-WC Distribution (Secondary) Slope Equaliser
 9-A-WC Secondary Output Attenuators
 Jumper or 9-A0 Diamond Line II secondary output selector if using only secondary output
 7-DC-862 Diamond Line II secondary output selector if using both secondary outputs
 9-A-WC/10-A-WC Return Input Attenuators (three locations)



DATA SHEET

C-COR CATV BROADBAND

01

C-COR BROADBAND

Australasian Office

2 Anzed Court,
Mulgrave VIC 3170
Australia

T: +61 3 8542 0600

F: +61 3 8542 0629

E: sales@c-cor.com.au

www.c-cor.com.au

India Office

316, Corporate Avenue,
Sonawala Lane Goregaon (E)
Mumbai 400 063
India

T: +91 22 26 86 27 71

E: sales@c-cor.com.au

Philippines Office

3rd Floor, BJS Building
1869 P. Domingo Street
Makati City 1207
Philippines

T: +63 2 836 0046

E: sales@c-cor.com.ph

© C-COR Broadband.

Flex Max is a trademark and the
C-COR logo is a registered trademark
of ARRIS Group Incorporated.

Issued February 2010.

Subject to change without notice.

C-COR Broadband is an authorised
distributor for ARRIS Group Incorporated
in South Asia, Philippines and Australasia.

*The product and company names are the
property of their respective owners.

	1	2	3	4	5	6	7	8	9	10	11	12	13	14	15	16		
G	4	A	8	2	8	D	4	0	-	C	A	M	N	9	2	C	I	Module Only
G	4	A	8	2	8	D	4	0	-	C	M	M	N	9	2	C	I	Version A
G	4	A	8	2	8	F	4	0	-	C	M	M	N	9	2	C	I	Version B

1-2	Platform
4A	GaAs Amp

3	Technology
8	HO GaAs 52dBmV output

4	Output
2	2 active ports

5	Bandwidth
8	870MHz

6	Frequency Split	
D	42/54MHz	a
F	65/85MHz	

a) Must select "C" in #9 block, Powering

7-8	Spacing
40	40dB gain

9	Powering
C	90VAC, 3A

10	Housing
A	none
M	9-NH15/l corrosion protected

11-12	Level Control
MN	None; Manual Level Control

a) Must select "F" in #6 block, Frequency Split.

13	Reverse
9	Hybrid Return

14	Internal/Output Tilt (reflects output tilt at highest frequency)
4	10dB

15-16	Surge Protection and Status Monitoring
CI	90V crowbar and status monitoring hooks