



C-COR® CHP Max5000

Product Overview

Converged Headend Platform



The CHP Max5000 converges hub, headend, and digital transport onto one scalable platform. The CHP Max5000 provides the highest density headend platform on the market, with up to 52% greater density than alternate offerings. Features include accelerated deployment of advanced services, innovative technology creating a converged high-density platform, simplified installation and management, optional redundant powering, hot-swappable modules, investment protection through its 2RU footprint, and universal management through a craft interface and SNMP.

This product overview highlights the CHP Max5000 platform components and all application modules, including the latest addition to the CHP Max5000 product line—the 1GHz CWDM 1291 and 1311 nm forward path transmitters, the first in the industry to be ITU G.695 compliant for CWDM spacing. This advanced CWDM transmitter is ideal for broadcast service providers looking to leverage their existing network infrastructure—without incurring the significant construction costs associated with additional fiber deployment—to support rapidly growing residential and business services.

Contact your ARRIS sales professional for a more detailed product data sheet on our 1 GHz CWDM transmitters and all CHP Max5000 application modules.

Applications

1 GHz Forward TX's (GFXV, GFXF, GFX-DXL) in Forward Segmentation Application (Unlocking Narrowcast Bandwidth)

Baseline HFC Configuration

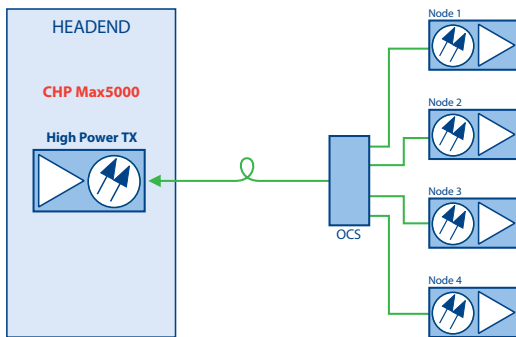

In a typical hybrid fiber coaxial network, one high power narrowcast transmitter may feed as many as four nodes, which together can serve nearly 2,000 subscribers.

Total Homes Passed: 20,000
Homes Passed/Node: 500
Nodes Required: 40
Narrowcast Group Size: 2,000 (4 nodes)
Number of Narrowcast Groups: 10
Broadcast Bandwidth: 293 Mbps
Narrowcast Bandwidth: $1254 \times 10 = 12,540$ Mbps
Total Bandwidth: 12,833 Mbps

Segmented Forward Path

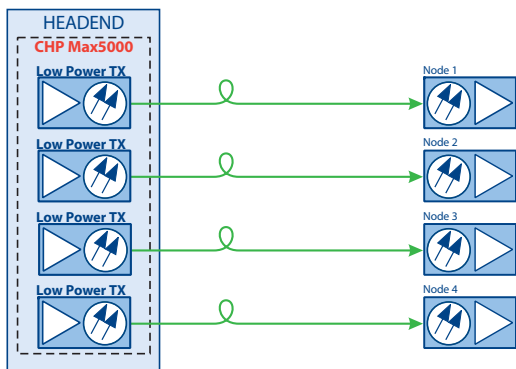

You can segment the forward path to provide more narrowcast bandwidth for advanced services by using one CHP Max5000 low power forward transmitter for each node, reducing the number of subscribers served by each transmitter to one quarter of those served before segmentation. This reduction increases bandwidth per subscriber by nearly 400%.

Total Homes Passed: 20,000
Homes Passed/Node: 500
Nodes Required: 40
Narrowcast Group Size: 500 (1 node)
Number of Narrowcast Groups: 40
Broadcast Bandwidth: 293 Mbps
Narrowcast Bandwidth: $1254 \times 40 = 50,160$ Mbps
Total Bandwidth: 50,453 Mbps

1 GHz CWDM Forward Transmitter

MSOs are continually pressured to increase the capacity of their HFC networks as subscribers demand HDTV, ever-increasing data download speed, business services, VoIP, and digital simulcast. The existing fiber infrastructure is rapidly becoming inadequate, if not already so, and at a cost of \$10,000/mile or more, new fiber construction may not be an option. CWDM technology is the way to go. By implementing CWDM, MSOs can combine multiple forward and return paths onto a single fiber.

The real advantage of CWDM technology can be seen in the ARRIS CWDM Multi-Wavelength Access Network, which is an even more targeted solution enabling MSOs to offer the full range of next-generation residential and business services by leveraging their existing network. Rigorously tested and field-proven, this new system delivers up to 10 multiplexed 20nm spaced CWDM wavelengths of analog forward, return, and GigE services on a single fiber today with capacity for future expansion.

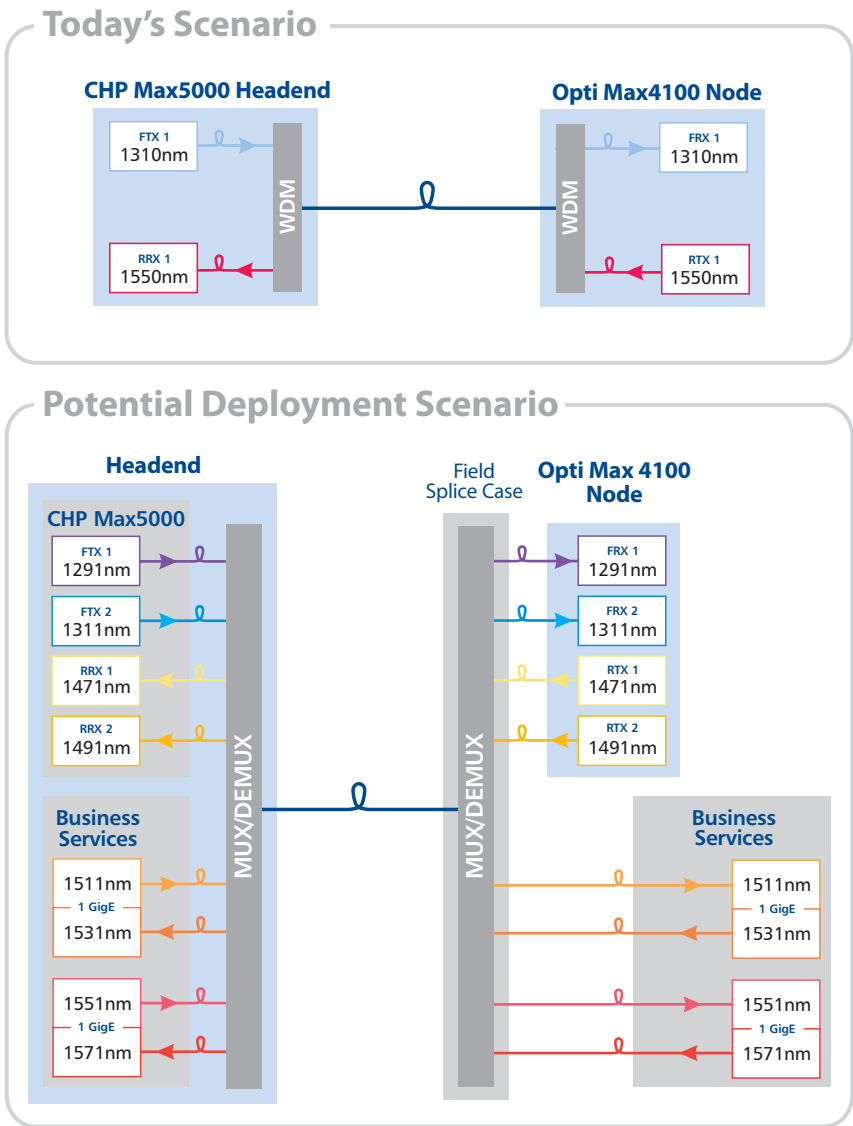

1550nm Supertrunking with XMOD TX, EDFA, GFRX

100km Single Channel Fiber Application

In the following diagram, the 79 NTSC channel output from the 1550nm XMOD transmitter is amplified by the 16dBm EDFA in the headend and then transmitted through a 45km fiber link to another 16dBm EDFA in the intermediate hub. This EDFA provides an additional gain of 16dB for the 55km fiber link to the forward receiver in the hub.

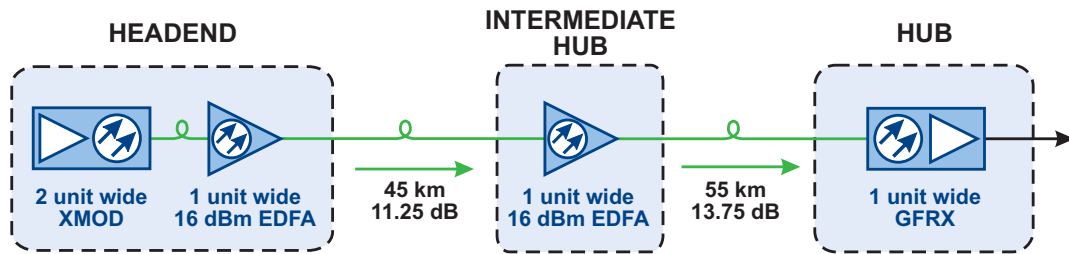

100km Split Channel/Single Fiber Application

In the following diagram, 40 NTSC channels from a 1545 nm XMOD TX and another 40 NTSC channels from a 1550nm XMOD TX are dense wave division multiplexed onto a single fiber and amplified by a 19dB EDFA in the headend and then transmitted through 45km fiber link to another 19dB EDFA in the intermediate hub. This EDFA provides an additional gain of 19dB to travel the 55km fiber link to the DWDM demultiplexer in the hub. The demultiplexer provides a 1545nm fiber optic input to a forward receiver and a 1550nm fiber optic input to the second forward receiver in the hub. The Split Channel application provides 3 dB CNR, 4 dB CTB, and 5 dB CSO performance advantages over the Single Channel application.

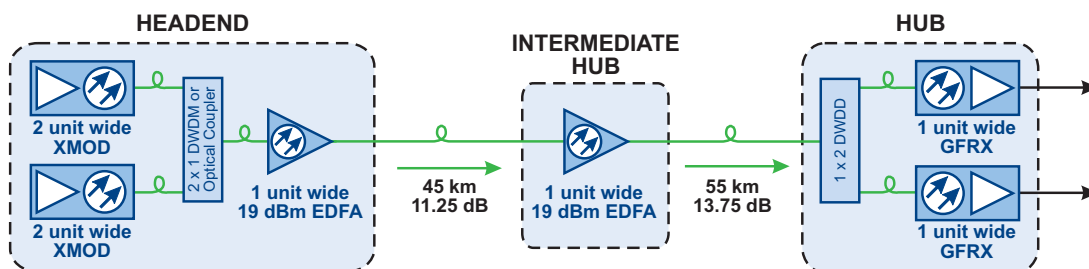

Digital Return Links with Reverse Receiver

In traditional analog return architectures, fiber optic nodes typically serve 500 homes or less. As demand for return services increases, these nodes can be modified by adding additional transmitters and segmenting return inputs. While this is definitely an advantage, the obvious disadvantages are that you need a separate fiber for each return path, and a return path receiver for each return transmitter. The cost of additional fiber and return path receivers can really add up. In addition, with the use of analog transmitters, link budgets are on the order of 10dB with maximum return optical links at 30km because of CNR limitations.

Direct Long Haul Digital Return

In this application, analog TXs and RXs are simply replaced with digital TXs and RXs. The same number of devices and the same amount of cable are required as in a traditional analog return system, but because digital transmitters and receivers are more robust—that is, less affected by noise and temperature—return optical links can be extended to as much as 100 km at 1550 nm without repeaters or optical amplifiers. Direct Long Haul Digital Return is a more cost-effective solution for extending optical links than adding EDFAs to an analog return system.

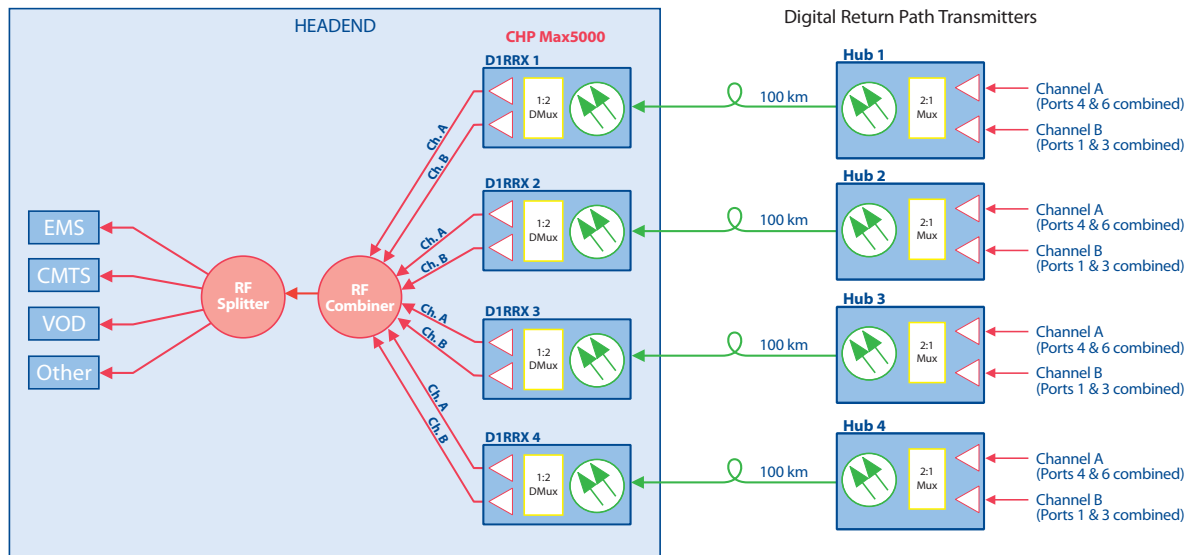

CWDM Return for Low Cost, Passive Optical Multiplexing with Limited Fiber

In this application, eight 1550nm digital return path TXs at 20nm spacing are each used for a direct short- or medium-haul return from node to hub. These eight separate return paths are then coarse wave division multiplexed onto one fiber for transport to the headend using the following wavelengths: 1471, 1491, 1511, 1531, 1551, 1571, 1591, and 1611 nm. Eight digital return receivers (CHP-D1RRX) installed in a CHP Max5000 in the headend complete this application. CWDM Digital Return is a more economical solution to DWDM on the ITU-grid and is ideal for topologies with limited fiber count.

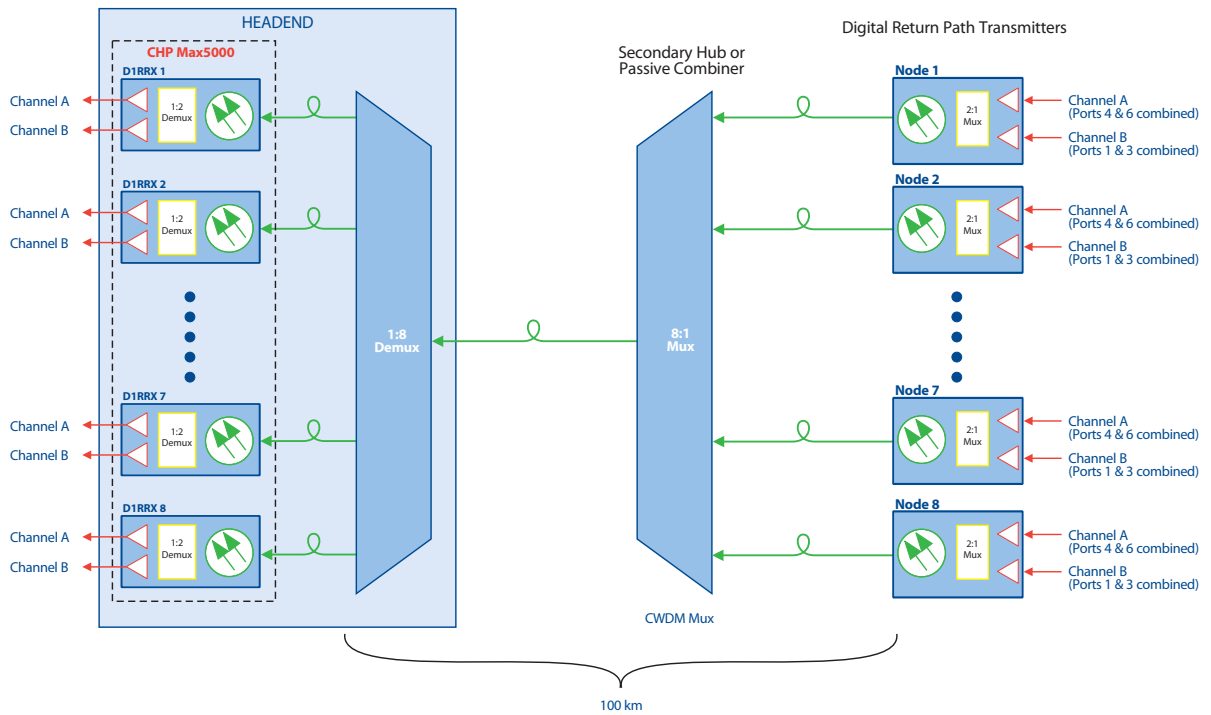

QAM overlay

In this example, narrowcast content from up to 20 QAM transmitters can be dense wave division multiplexed onto a single fiber in the headend and then transmitted up to 65km to a hub. An EDFA in the hub amplifies the optical signal, and the wavelength of the associated narrowcast transmitter is demultiplexed. The output of the demultiplexer is multiplexed with the broadcast signal of the EDFA in the hub to combine both signals onto a single fiber going to the node.

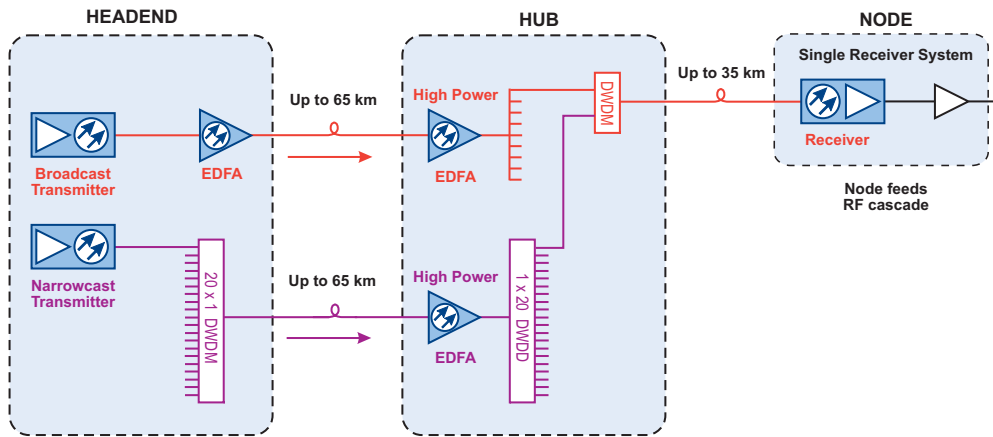

In the dual receiver architecture, the major difference from the previous example is that the broadcast and narrowcast signals are not dense wave division multiplexed onto the same fiber in the hub. Instead, the broadcast and narrowcast signals are independently routed through the headend and hub to separate receiver in the node. The RF signals are then combined in the node.

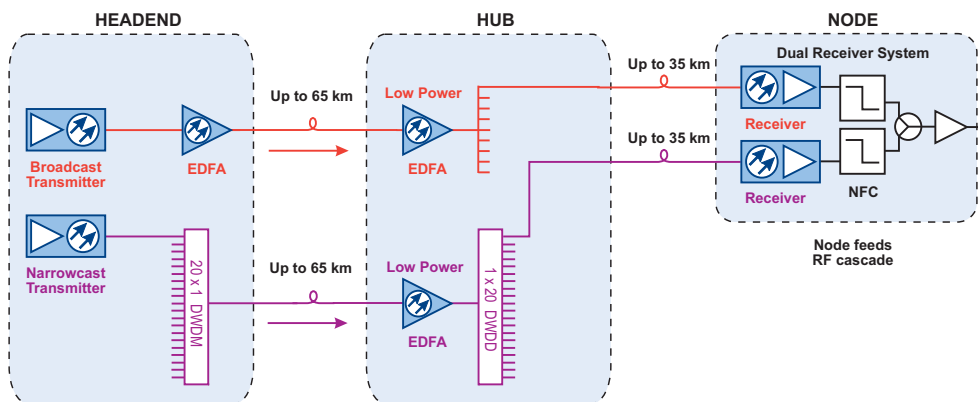

CHP Max5000 Chassis

The 2RU 19-inch CHP Max5000 chassis provides 10 module slots for application modules, 2 for isolated redundant power supplies, and 1 for a management module.

- Standard 40RU rack holds up to 200 CHP Max5000 transmitters or 400 return receivers
- Chassis available in front or rear fiber version
- Optional fiber tray and shield protect and manage fiber in the front fiber chassis
- Thermal design provides a wide operational temperature range for maximum reliability
- A plenum with eight large fans create more airflow and offer better reliability than module-based fans; in the event of a fan failure, application modules—and the services you provide—remain in operation.

Separate interfaces built into the back panel of each chassis direct power to and convey element management information to/from installed modules.

Universal slots accept the application modules in virtually any combination to accommodate a variety of service delivery requirements.



Rear Fiber Chassis
CHP-CHASSIS-19Q or
CHP-CHASSIS-19Q-B



Front Fiber Chassis
CHP-CHASSIS-R-19Q

CHP Max5000 Power Supply

CHP Max5000 isolated, load-sharing, redundant power supplies are available with either auto-sensing (110 to 220V) AC or DC (-72 to -36VDC) input. One power supply supports a completely loaded chassis, while two offer power redundancy eliminating service interruption if one power supply or line-in feed service fails.

CHP power supplies are located on the far right side of the chassis behind the Craft Management Module (CMM-1) or System Management Module (SMM-1). Isolated outputs allow the primary and redundant supplies to operate in a power-sharing configuration. Should the primary power source fail, a second power supply provides all necessary DC power. AC and DC power supplies should not be installed in the same chassis.



AC Power Supply
CHP-PS/AC1-Q

DC Power Supply
CHP-PS/DC1-Q

CHP Max5000 Management Modules

The CHP Max5000 management modules are available in two models. The Craft Management Module (CMM-1) offers local monitoring and configuration along with a PC compatible graphical user interface (GUI). The System Management Module (SMM-1) offers all the functionality of the CMM-1 plus remote management using SNMP with HMS-compliant MIBs for use with an external element manager or remote access to the CMM-1 interface using an IP connection through the Ethernet interface from the remote GUI software. The CMM-1 and SMM-1 have an auto-configuration feature that allows you to replace an auto-configuration supported application module and the management module automatically restores the configurable parameters of the previously installed module. All management modules offer an RS-485 interface for interconnecting multiple chassis at one site for single point control from an SMM-1.

The CHP Max5000 GUI simplifies system installation, provides monitoring on easy to read screens and displays all critical module information to assist in operational as well as inventory management. A complete equipment manual is also included in the Craft Management Software (CMS) bundle for access on a PC with either the Windows® NT 4.0, 2000 SP1, or XP Professional operating system.

The SMM-1 provides remote access to the CMM-1 interface using an IP connection through the Ethernet interface from the remote GUI software without requiring the capital expenditure of SNMP element manager. To monitor up to 10 chassis, install 1 CMM-1 in up to 9 chassis and 1 SMM-1 in a tenth chassis. Then, daisy-chain the chassis together and use an Ethernet connection to program, provision, monitor, and manage your CHP Max5000 equipment via an SNMP element manager. Managing more than 10 chassis is accomplished by using a 10baseT Ethernet hub or switch between the Remote Management System and the chassis containing the SMM-1 module.



**Craft Management Module
CHP-CMM-1**

Craft Management Software and CORView



1 GHz Application Modules

The CHP Max5000 Advanced 1 GHz Transmitter Suite includes the 1 GHz Variable Forward Path Transmitters, 1 GHz 1291 and 1311 nm CWDM Forward Path Transmitters, 1 GHz Fixed Output Forward Path Transmitter, and 1 GHz Forward Path QAM Transmitters, enabling broadband service providers to increase forward capacity for HDTV over previous program offerings, thereby allowing typically 40% increase over current HDTV channels in a lineup. CHP Max5000 1 GHz transmitters are dual-input, hot-swappable transmitters with integrated management through the local Craft GUI and remote management via SNMP HMS-compliant interface for external connection to an element manager.

The ARRIS revolutionary variable optical output power range enables operators to reduce spare inventory up to 60 percent, reduce the need for optical attenuators, and account for unexpected link loss during system implementation. These benefits translate into significant CapEx and OpEx savings, and provide maximum flexibility for deploying advanced interactive services. The 1 GHz Transmitter's dual-input capability provides isolation that is much superior to alternative offerings, enabling simultaneous advanced service deployment of video and telephony without cross-talk impairments. In addition, integral high isolation eliminates having to add external devices to achieve similar performance, thereby lowering CapEx even further and reducing system complexity.

1 GHz CWDM Forward Path Transmitters

The advanced 1 GHz CWDM Transmitter is ideal for MSOs that need to support a rapidly growing residential and business services on a fiber-scarce HFC plant.

Provides the capability to multiplex two forward and multiple analog return wavelengths on a single fiber

1311 nm and 1291 nm CWDM transmitters

1311 \pm 4 nm with variable output power levels of 4, 6, 8, 10, or 12 dBm, output levels can be adjusted from the maximum output power to 2 dB below this level in 0.25 dB steps

1291 \pm 4 nm with variable output power level of 8 dBm, output power level can be adjusted from 6 to 8 dBm in 0.25 dB steps

By deploying 1311 nm CWDM transmitters today, adjacent ITU channels can be reserved for future CWDM applications

ITU G.695 standards compliant

Variable optical output power range for spare inventory reduction and flexibility to account for unexpected link loss during system implementation

Superior performance to facilitate 256-QAM digital channel transmission capability

Plug-in equalizer and attenuators for RF gain control and front panel RF testpoint for convenient monitoring



CWDM 1 GHz Forward Path TX
CHP-GFXV-1311-xx-S

1 GHz 1310nm Variable Forward Path Transmitter

These 1 GHz forward path transmitter are available with a maximum output power of 2, 4, 6, 8, 10, and 12 dBm. The output level can be adjusted from the maximum output level to 2 dB below this level in 0.25 dB steps.

Superior performance to facilitate 256-QAM digital channel transmission capability

Plug-in attenuators for RF gain control and front-panel RF testpoint for convenient monitoring

Dual high isolation input

Also available in a front fiber version

1 GHz 1310nm Fixed Output Forward Path Transmitter

The 1 GHz Forward Path Transmitter, series of fixed output rear fiber transmitters, has fixed output levels of 13, 14, and 15 dBm.

High isolation for minimum cross talk.

Unlock narrowcast bandwidth to accelerate deployment of advanced services

Dual RF inputs—Primary input for broadcast; Secondary input for narrowcast

GUI configurable automatic drive control (ADC)

Economical fixed output version of the variable output series transmitter

Also available in a front fiber version

1 GHz Value Line 1310nm Fixed Output Forward Path Transmitter

The 1 GHz Forward Path Transmitter, the value line series of fixed output rear fiber transmitters, has fixed output levels of 2, 4, 6, 8, 10, and 12 dBm.

Unlock narrowcast bandwidth to accelerate deployment of advanced services

Dual RF inputs—Primary input for broadcast; Secondary input for narrowcast

GUI configurable automatic drive control (ADC)

Economical fixed output version of the variable output series transmitter

1 GHz Variable Forward Path TX

CHP-GFXV-Dxx-xx-xx



1 GHz Fixed Forward Path TX

CHP-GFX-D-xx-xx



1 GHz Fixed Forward Path TX

CHP-GFXF-D-xx-S



1 GHz Forward Path QAM Transmitter

The advanced 1GHz QAM Transmitters are ideally suited to transport digitally encoded video (16/64/256-QAM) and QPSK data from the headend to a hub or node.

Accept narrowcast QAM signals, telephony, etc. from 550 to 1002 MHz and convert the RF input to an optical output at DWDM wavelengths available at odd ITU channels 21 through 35. ITU channels 37 through 61 may be available upon request.

Optical output power of 10dBm provides a transmitter reach of up to 150 km with an EDFA.

Dual-input capability provides isolation that is much superior to alternative offerings, enabling the possibility to use "broadcast" QAM channels on one input, while using "narrowcast" QAM channels on the other input without cross-talk impairments. The high isolation eliminates having to add external devices to achieve similar performances, thereby lowering CapEx and reducing system complexity.

Superior performance to facilitate 256-QAM digital channel transmission capability

10dBm optical output DWDM wavelengths available at odd ITU channels 21 through 61

Plug-in attenuators for RF gain control and front-panel RF testpoint for convenient monitoring

1 GHz Forward Path QAM TX CHP-GQTX-10-S-xx



1 GHz Redundant Forward Path Receiver

C-COR CHP Max5000 1GHz Redundant Forward Receivers, designed to accept a single optical forward path signal from a CHP Forward Path Transmitter, can operate as either a stand-alone receiver with a single optical path or can be configured as a redundant receiver with the addition of a second module and a Redundant Communications Link Cable (RCL2) to maintain uninterrupted service availability in the event of optical path or hardware failure.

Extending bandwidth from 870MHz to 1GHz increases overall forward capacity by 16% and the digital spectrum by 40%

Automatic switchover time for optical path or hardware failure is less than or equal to 50ms.

Offers operators the flexibility to set the optical input and RF output thresholds for switching to the redundant module and may be located in the same CHP chassis or in a different rack located within the maximum RCL2 length of 6 meters (20 feet).

An alarm is generated if either the optical input power or RF output power exceeds a user-defined major high limit or drops below a user-defined major low limit.

Designed for both 1310nm and 1550nm network architectures with an input power range from -10 to 4dBm.

Provides a high RF output up to 1GHz with a noise contribution of less than $8\text{pA}/\text{Hz}^{0.5}$ eliminating the need for additional RF amplification when combining many circuits.

Front-panel RF testpoint for convenient monitoring

The front panel has module and channel status LEDs, and up and down gain adjustment buttons, which can be locked out by the local Craft Management Graphical User Interface for security purposes.

Exceptional price/performance ratio

1 GHz Redundant Forward Path RX CHP-GFRX-S



1 GHz 3-Input Forward Path RF Amplifier

The CHP Max5000 Advanced 1GHz 3-Input Forward Path RF Amplifier is a hot-swappable module that can be used as a key system component in a headend or hub environment to provide RF signal amplification. The innovative 3 RF inputs, 1 broadcast and 2 narrowcast, support layered services such as SDV, VOD, and HSD. This amplifier is designed to provide system operators a low cost way to overcome network losses, with minimal degradation to system performance, caused by combining and splitting networks that are typically found in HFC headends/hubs.

3-Input Forward Path RF Amp
CHP-GAMP3



1 GHz single output with forward passband of 50 to 1002 MHz

The maximum gain for the broadcast port is 20 dB, the narrowcast port are 10 dB

1 broadcast input and 2 narrowcast inputs supports layered narrowcast services

Superior CNR and distortion performance

Gain adjustable by 6 dB in 0.25 dB steps via Craft GUI or SNMP

Superior reverse port-to-port isolation enables the combination of multiple narrowcast sources to reduce external signal combining and simplify cable wiring.

Front-panel RF output testpoint for convenient monitoring

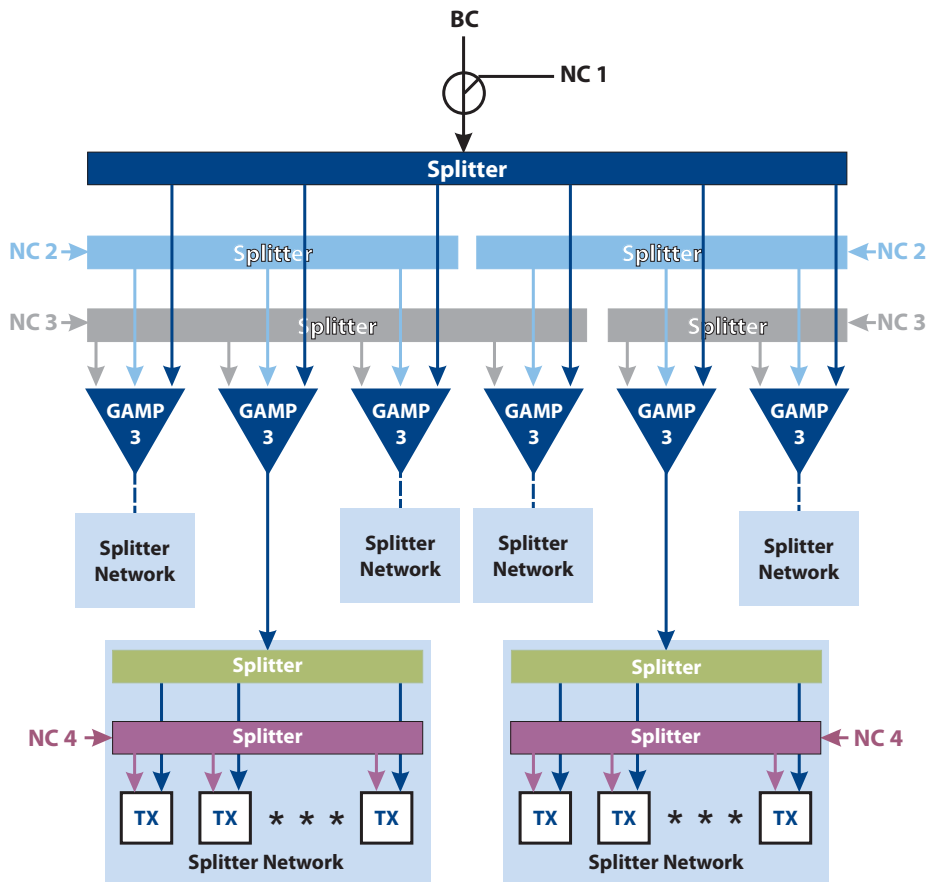

Layered Narrowcasting Configuration

1550nm Externally Modulated Transmitters

CHP Max5000 Dual Output 1550nm Externally Modulated double-width Transmitters offer scalable long distance optical solutions.

Laser options enable 1555 ± 5 nm for WDM, 1545 ± 1 nm for Red/Blue, and 1550 ITU for DWDM applications providing a variety of solutions for fiber challenged long distance applications.

The CHP-XMOD models have a RF bandwidth from 40 to 870MHz and the CHP-GMOD models have an extended bandwidth from 40 to 1002MHz.

Modular system optimized for use with CHP Max5000 EDFA series modules

Power requirements at geographical reach distances of up to 100 km—the preferred solution for HFC or FTTX applications.

Advanced adjustable SBS from 12 to 18dB provides the flexibility to optimize link performance with minimal inventory providing both CapEx and OpEx savings.

Advanced adjustable SBS from 12 to 18dB for maximum performance and minimal inventory

1550nm Externally Modulated TX

CHP-XMOD-xxx-xx-x

CHP-GMOD-xxx-xx-xx



EDFA

CHP Max5000 Erbium-Doped Fiber Amplifiers (EDFAs) offer a scalable optical amplification solution. The CHP Max5000 EDFA series is designed for use with CHP Max5000 1550nm transmitters.

Providing low noise, integrated element management capability, reduced rack space, and power requirements.

Offered with single, dual, and triple-width modules based on the configuration option.

Available with or without constant gain (Constant gain modules can be set for either constant gain or constant power, whereas modules without constant gain only have a constant power mode. In constant gain mode, EDFAs amplify the optical input by a fixed amount regardless of optical input power. In constant power mode, EDFAs provide a consistent optical output power regardless of optical input power.)

Nominal output powers from 13dBm to 20dBm per port

EDFA

CHP-EDFA-xx-xx-x-x



Dual Return Path Receivers

C-COR CHP Max5000 Dual Return Path Receivers are an integral part of return path system applications and are available as either a standard or redundant module. Advanced two-way services—such as video on demand, high speed Internet access, and telephony—require superior return path delivery capacity and performance.

High RF output and high efficiency optical performance for excellent carrier-to-noise performance

Up to 20 separate receiver channels per chassis and 400 receivers per rack for high density and reduced cooling and power costs

The redundant modules enable optical path and hardware protection for mission critical applications such as VoIP and business data provisioning

Optical and RF switches will alternate between diverse paths when an optical path or module hardware fault is detected. Switch time is less than 50 milliseconds to ensure telephony call hold time.

Module pairs can reside in the same CHP Max5000 chassis or in separate chassis up to 6 meters (20 feet) apart through interconnection with the RCL2 cable

Redundant version integrates optical path and RF switching on same module

Redundant pair module option can reside in same chassis or separate chassis

5 to 200 MHz transmission bandpass

Front-panel RF testpoint for convenient monitoring

RF output level adjustment per channel via front panel control, local or remote IP access to Craft GUI, or SNMP

Dual Return Path Receiver
CHP-2RRX-S (standard)
CHP-R2RR-xx (redundant)



Ordering Information

Platform Components

Component Type	Model Series	Description
Chassis	CHP-CHASSIS-19Q	Rear fiber access chassis and backplane with eight dual-speed fans for quieter operation.
	CHP-CHASSIS-19Q-B	Same as above but has holes for optional offset mounting bracket (P/N CHP-OFFBKT-19).
	CHP-CHASSIS-R-19Q	Front fiber access chassis and backplane with eight dual-speed fans for quieter operation.
Offset Bracket	CHP-OFFBKT	Bracket can be used to extend a CHP-CHASSIS-19Q-B chassis either 4 or 6 inches out from the rack.
23-in External Bracket	CHP-EXTBKT-23	Bracket adapts 19-inch chassis to install in a 23-inch rack.
Power Supply	CHP-PS/AC1-Q	Isolated power supply accepting 110/220VAC input.
	CHP-PS/DC1-Q	Isolated power supply accepting -48VDC input.
CORView	COR-SYS-SRV	CORView network management system including system server, My SQL license, and 5 client licenses
	COR-SYS-CLT-5	CORView network management system — 5 client licenses
Craft Mgmt. Module	CHP-CMM-1	Allows local monitoring and management via laptop computer connected to the RS-232 connector on the front of the CMM. The CHP-CMM-1 adds the auto-configuration feature that allows you to replace an auto-configuration supported application module and the management module automatically restores the configurable parameters of the previously installed module.

Platform Components

Craft Mgmt. Software	CHP-CMS-1	Software that provides graphical user interface (GUI) and enables local communication for module setup and monitoring of a CHP Max5000 shelf from a portable computer.
System Mgmt. Module	CHP-SMM-1	Provides all CMM-1 functionality and SNMP port for remote management. SMM-1 also provides remote access to the CMM-1 interface using an IP connection through the Ethernet interface on the back of the shelf from the remote GUI software. The CHP-SMM-1 adds the auto-configuration feature that allows you to replace an auto-configuration supported application module and the management module automatically restores the configurable parameters of the previously installed module.

Application Modules

Module Type	Model Series	Description
Forward Transmitters	CHP-GFXV-1311-xx-S CHP-GFXV-1291-08-S	1291 and 1311 nm CWDM dual-input, variable output 1 GHz forward TXs linearized to 550MHz. "xx" indicates max. optical output power of 4, 6, 8, 10, or 12dBm. 1291 nm TX is only available with a variable output level of 8dBm. SC/APC connector.
	CHP-GFXV-D-xx-S CHP-GFXV-DF-xx-S	1310nm dual-input, variable output 1 GHz forward TXs linearized to 550MHz. "F" indicates a Front Fiber version. "xx" indicates max. optical output power of 4, 6, 8, 10, or 12dBm. SC/APC connector.
	CHP-GFXF-D-xx-S	1310nm dual-input, fixed output 1 GHz forward "Value Line" series TXs linearized to 550MHz. "xx" indicates optical output power of 2, 4, 6, 8, 10 or 12dBm. SC/APC connector.
	CHP-GFX-1311-xx-S	1311 nm CWDM dual-input, fixed output 1 GHz forward TXs linearized to 550MHz. "xx" indicates max. optical output power of 13, 14, or 15dBm. SC/APC connector.
	CHP-GFX-D-xx-xx CHP-GFX-DF-xx-S	1310nm dual-input, fixed output 1 GHz forward TXs linearized to 550MHz. "F" indicates a Front Fiber version. "xx" indicates optical output power. Output powers of 13, 14, and 15 dBm. SC/APC connector only available for CHP-GFX-DF-xx-S; last "xx" represent the optical connector for CHP-GFX-D-xx-xx (S=SC/APC connector, AF=FC/APC).
	CHP-GFX-DXL-xx-S	1310nm dual-input, fixed output 1 GHz forward TXs linearized to 870MHz. "xx" indicates optical output power. Output powers of 2, 4, 6, 8, 10, 12, 13, 14, and 15dBm. SC/APC connector.
	CHP-GQTX-10-S-xx	Dual-input 10dBm output 1 GHz forward QAM TX, where "xx" indicates odd ITU channel. SC/APC connector.
	CHP-XMOD-x5-xx-x	External modulated forward TX. First "x" is wavelength; 4=1545 ± 1 nm, 5=1555 ± 5 nm. Second "x" is TX reach; M=65 km, X=100 km. Third "x" is channel loading; blank=80 NTSC Ch, A=112 Ch, L=40 NTSC low-band, U=40 NTSC hi-band. The last "x" represents the optical connectors (S= SC/APC, E=E2000).
	CHP-XMOD-Dxx-M-x	External modulated forward TX with channel loading of 80 NTSC channels. "xx" is odd ITU channels 21 to 29, 37, 39. "x" represents optical connectors (S=SC/APC for all models, E=E2000 for ITU Ch 29).
	CHP-GMOD-x5-Mx-x	1 GHz external modulated forward TX. First "x" is wavelength; 4=1545 ± 1 nm, 5=1555 ± 5 nm. "M" is TX reach of 65 km. Second "x" is channel loading; blank=80 NTSC Ch, A=112 Ch, L=40 NTSC low-band, U=40 NTSC hi-band. The last "xx" represents the optical connectors (S= SC/APC, AF=FC/APC, E=E2000).
	CHP-GMOD-Dxx-M-x	1 GHz external modulated forward TX with channel loading of 80 NTSC channels. "xx" is odd ITU channels from 21 to 29, and 39. "x" represents optical connectors (S=SC/APC for all models).

Application Modules

Return Receivers	CHP-2RRX-S	Dual return RX accepting 1200nm to 1620nm optical input. SC/APC connectors.
	CHP-R2RR-xx	Redundant dual return RX accepting 1200 to 1620nm optical input. "xx" represents optical connectors (S=SC/APC, UF=FC/UPC).
	CHP-D1RRX-S	Redundant 1:2 TDM return RX accepting 1465 to 1615 nm optical input. S=SC/APC connector.
	CHP-1RRX-S	Single front fiber access return RX accepting 1200nm to 1620nm optical input. S=SC/APC connector.
	CHP-R2RRFF-S	Redundant front fiber access dual return RX accepting 1200 to 1620nm optical input. S=SC/APC connectors.
Redundant Forward RXs	CHP-GFRX-S	1 GHz single forward redundant RX accepting 1200 to 1620nm with an input level from -10 to 4dBm. SC/APC connector.
	CHP-RFRX-S	870MHz single forward redundant RX accepting 1200 to 1620nm with an input level from -10 to 4dBm. SC/APC connector.
Return Transmitters	CHP-RTX3-10-S	1310nm dual-input return TX. 10dBm output. SC/APC connector.
	CHP-RTX5-10-S-xx	1550nm dual-input return TX. 10dBm output. "xx" indicates odd numbered ITU channel (21 through 49). SC/APC connector.
EDFAs	CHP-EDFA-CG-xx-1-S	EDFA with constant gain or constant power operating modes. Available with output power of 13, 16, 19, or 22dBm with 1 port. S=SC/APC connector.
	CHP-EDFA-xx-x-x	EDFA with constant power operating mode. "xx" represents output power of 16dBm (1, 4, or 8 ports), 19dBm (1, 2, or 4 ports), 20dBm (8 ports). Next "x" indicates number of ports. Last "x" represents optical connectors; S=SC/APC (2 or 4 ports), L=LC/APC (4 or 8 ports).
RF Amplifiers	CHP-GAMP3	1 GHz 3-Input forward path RF amplifier.

Contact your ARRIS sales professional for data sheets on CHP application modules.

C-COR® CHP Max5000 Product Overview



The capabilities, system requirements and/or compatibility with third-party products described herein are subject to change without notice. ARRIS, the ARRIS logo, C3™, C4™, CableEdge®, Cadant®, C-COR®, CHP Max®, Cornerstone®, CXM™, D5™, Digicon®, Flex Max®, Keystone™, MONARCH®, n5™, nABLE™, NSM®, nVision®, PLEXIS®, Regal®, ServAssure™, TeleWire Supply®, Touchstone®, VoiceAssure™, and WorkAssure™ are all trademarks of ARRIS Group, Inc. Other trademarks and trade names may be used in this document to refer to either the entities claiming the marks and the names of their products. ARRIS disclaims proprietary interest in the marks and names of others. © Copyright 2008 ARRIS Group, Inc. All rights reserved. Reproduction in any manner whatsoever without the express written permission of ARRIS Group, Inc., is strictly forbidden. For more information, contact ARRIS.

CHPVIEW-D-0208

