

Flex Max331

1GHz Line Extenders



- **1 GHz technology**
- **Supports future 85/105 MHz architectures**
- **Upgrades C-COR legacy 750 MHz E700 series and 870 MHz Flex Max330 series line extenders to 1 GHz**
- **ALC, TLC, and NLC options**
- **Supports major EMS protocols**

C-COR introduces the Flex Max331 Line Extenders, a new family of 1 GHz strand-mount line extenders with the superior quality and exceptional performance customers have come to expect with C-COR RF amplifiers. 1 GHz will enable broadband service providers to increase forward capacity for HDTV over previous program offerings, thereby allowing typically 40% increase over current HDTV channels in a lineup.

Flex Max331 Line Extenders are available as both complete units for customers designing new system builds and as drop-in RF modules for a 1 GHz upgrade of C-COR legacy FlexNet 750 MHz 700 series line extenders or Flex Max330 870 MHz line extenders. Flex Max331 Line Extender operating specifications, such as gain and tilt, are maintained at 750 MHz and 870 MHz, with extended gain and tilt out to 1002 MHz. These unique design considerations enable reuse of legacy line extender housings and existing spacing, which in turn eliminates the additional cost of resplicing, making the Flex Max331 Line Extender drop-in RF module an ideal choice for 1 GHz system upgrades.

Flex Max331 Line Extenders meet the requirements for modern HFC multi-transport networks through applied robust Gallium Arsenide technology, which improves system performance and drives total system costs down. With its 35dB operational gain, the Flex Max331 covers all applications for modern high performance line extenders.

Flex Max331 Line Extenders are available with three level control options: automatic level control (ALC), thermal level control (TLC), and no level control (NLC). To further facilitate upgrades when the Flex Max331 Line Extender is purchased as a drop-in module, the ALC model has two pilot levels common to legacy line extenders.

In addition, Flex Max331 Line Extenders will be available with an 85/105 MHz option, which will double return bandwidth for ever-expanding broadband networks.

Features

- Economical choice for both legacy system upgrades and new builds
- 85/105 MHz option for future architectures
- GaAs technology results in fewer active components, improved system performance, and reduced total system costs
- High performance push-pull return amplifier for a wide range of signals on the return path
- Capable of handling 15 A of AC through-current for tough powering demands for new builds and 13 A for upgrades
- Optional surge protection module decreases amplifier failure rates by dissipating surges due to lightning, power transients, and other causes
- Three-position return switch for ingress troubleshooting
- -20 dB or -25 dB forward and return testpoints for accurate and repeatable measurements
- Ability to use CW signal or QAM signal for pilot frequency

Functional Block Diagram

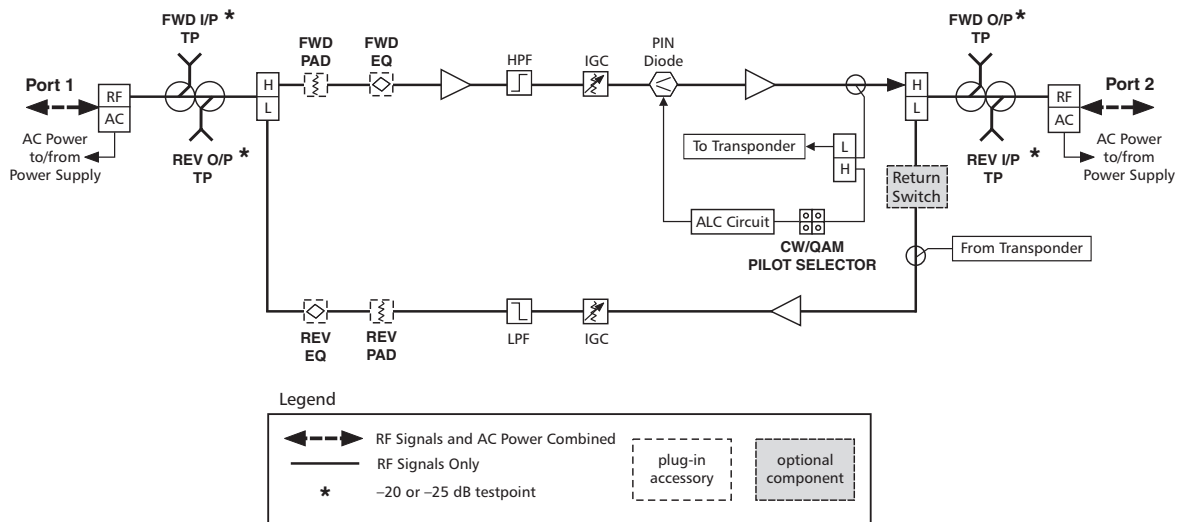

Application

Flex Max331 Line Extenders amplify and control forward feeder signals from a network amplifier or other line extender. Return path circuitry of the Flex Max331 Line Extender also amplifies return signals from the subscriber.

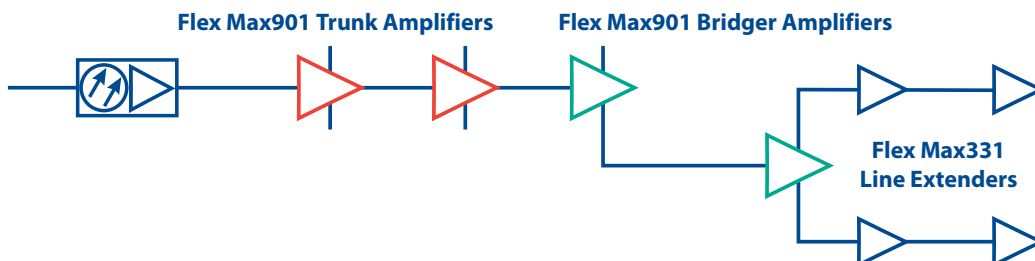

Specifications (ALC Version)

	Forward	Return
General		
Bandwidth, MHz	54 to 1002	5 to 42
AC Current Passing, A (Note 1)	15	15
Typical Operating Conditions		
Operational Gain, dB (Note 2)	35	18
Channels, Number of NTSC (Note 3)	79	6
Operating Levels (recommended)		
Frequency, MHz	1002/870/750/550/54	42/5
Input, dBmV, min. (Note 4)	17/15.4/14.4/12.6/10.2	17/17
Output, dBmV (Note 5)	52/49.5/47.5/44/35	35/35
Performance Specifications @ Recommended Levels		
(Temperature Range: -40 to 60°C)		
Carrier-to-Interference Ratio, dB		
Composite Triple Beat	77	84
Second Order Beat (F1 ± F2)	—	—
Cross Modulation (per NCTA std.) (Note 6)	72	74
Third Order Beat (F1 ± F2 ± F3)	—	—
Composite 2IM	75	80
Composite Intermodulation Noise (CIN) (Note 7)	73	—
Composite Intermodulation Noise (CIN) (Note 8)	79	—
Noise, 4MHz, 75Ω (Note 9)	68/66.4/65.4/63.6/59.2	70.5
Noise Figure, dB (without EQ) (Note 9)	7/7/7/7/9	5.5
Full Gain, dB (without EQ and ALC)	39.5	19
Factory Alignment (with ALC reserve, without EQ)		
Cable Loss, dB @ 1002MHz	13	—
Flat Loss, dB	23	19
Gain Slope, dB	-0.25 to 0.75	-0.5 to 0.5
Flatness, dB	±0.5	±0.5
Return Loss, dB, min.	16	16
Powering Requirements, max./typ. (Note 10)	With Active Return, EMT, and Return Switch	With Active Return
AC Voltage, 60Hz	@ 90V @ 60V	@ 90V @ 60V
AC Power, Watts	26.7/26.1 26.2/25.6	24.9/24.4 24.4/23.9
AC Current, mA	370/355 600/570	340/335 535/520
DC Current, mA @ 24V ± 0.5V	935/915 935/915	870/850 870/850
Automatic Level Control		
Range, dB @ 1002MHz	+3.5/-4.5	—
Accuracy (-40 to 60°C), dB	±0.5	—
Operating Level Range (from specified levels), dB	±4.5	—
Pilot Frequency Band (recommended), MHz	499.25 (single channel)	—

Specification Document Number 1500171 Rev M

Notes:

- AC current passing is shown with factory complete line extenders. AC current passing is 13A for Flex Max331 RF modules used to upgrade E700 series line extenders.
- Spacing is at the highest frequency with SEQ-1G-xx installed. Return spacing includes losses due to housing, diplex filters, and MEQ-42-xx.
- NTSC video channels occupying the appropriate frequency spectrum per specified number of channels.
- Recommended minimum forward input level at 1002MHz including loss due to equalizer.
- Recommended maximum return output level at 42MHz including loss due to equalizer.
- Cross modulation specification number indicates typical cascade performance.
- System operating with digitally compressed channels or equivalent broadband noise from 550 to 1002MHz at levels 6dB below equivalent video channels will experience a composite distortion (CIN) appearing as noise in the 54 to 550MHz frequency spectrum.
- System operating with digitally compressed channels or equivalent broadband noise from 550 to 870MHz at levels 6dB below equivalent video channels will experience a composite distortion (CIN) appearing as noise in the 54 to 550MHz frequency spectrum.
- The Noise Figure and C/N specifications are typical within the specified passband.
- Power supply is internal to RF module. Refer to drawing #333995-32. For 60VAC powering: AC Power consumption in Watts divided by a factor of 43 = Amps required. For 90VAC powering: For £ 67VAC, 1.03 x (AC power consumption in watts divided by voltage) = Amps required. For 67 - 90VAC, AC power consumption in Watts divided by 65 = Amps required.
- TLC specifications (P/N 1500417) and NLC specifications (P/N 1500519) are also available. Contact your C-COR sales professional.

Specifications are subject to change without notice

Ordering Information

			1	2	3	4		5	6	7	8	9	10	11	12
F	M	L	1	G	x	x	-	x	x	x	x	P	x	x	N

1 Series	
1	Flex Max331 series

2 Bandwidth	
G	1002 MHz

3 Spacing		
7	35 dB	a,c
8	38 dB	b,c
a) Must select "A1", "KB", or "L0" in #5-6 block, Level Control . b) Must select "NA" in #5-6 block, Level Control . c) 13 dB factory equalization		

4 Frequency Split	
J	42/54 MHz
N	65/85 MHz
Q	55/70 MHz

5-6 Level Control	
A1	TLC (thermal level control)
KB	439.25 MHz NTSC TV (automatic level control)
L0	499.25 MHz NTSC TV (automatic level control)
NA	None (no level control)
MB	645.00 MHz QAM (automatic level control)
RM	711.00 MHz QAM (automatic level control)
SD	609.00 MHz QAM (automatic level control)

7 Return		
4	18 dB active gain	a
6	18 dB active gain with return switches	b
a) Select "6" if future element management transponder is desired. b) Operation of return switches requires a transponder.		

8 Output Configuration	
M	One output, -20 dB internal testpoints
N	One output, -25 dB internal testpoints

9 Powering		
P	1.0 A, 60-90 V, 50/60 Hz power supply	a
a) An optional surge protector (P/N 162355-03) is available and must be ordered separately.		

10 Housing		
A	None	a
R	2-port Flex Max, 1 GHz, flat lid, -20 dB internal testpoints	
a) Select "1" #10 block, Housing Finish . Required when ordering RF module only.		

11 Housing Finish		
1	Standard (or N/A)	a
4	Corrosion protected	
a) Required when ordering RF module only.		

12 Element Management		
N	EMS capable	a,
a) Transponder sold separately: AM protocol (P/N 810-0354-01A) HMS protocol (P/N 810-0354-01H)		

An HMS/AM protocol Value Max transponder is available to monitor and control the Flex Max331 Line Extender. Contact your C-COR sales professional for details and to discuss how our exciting new 1 GHz products can add value to your network.

Americas Headquarters

60 Decibel Road • State College • Pennsylvania • 16801 • USA
 T: 1-814-238-2461 T: 1-800-233-2267 F: 1-814-238-4065

EuroPacific Headquarters

Transistorstraat 44-V • 1322 CG Almere • The Netherlands
 T: 31-36-546 1111 F: 31-36-536 4255

Flex Max is a trademark and the C-COR logo is a registered trademark of C-COR Incorporated.
 Copyright © 2006 C-COR Incorporated. All rights reserved.



www.c-cor.com