

Flex Max320™

Line Extenders



- **GaAs technology**
- **9- and 7-LH housing compatibility**
- **Plug-in duplex filters**
- **High current-passing capability**

The Flex Max320 Line Extenders provide excellent forward and return path performance in a compact end-of-line solution. Flex Max320 Line Extenders amplify RF signals and provide slope and gain control for unity gain in both forward and return paths. The return path circuitry, installed on the PC board, uses a hybrid amplifier with an improved compression point and bit error rate (BER) for digitally loaded traffic over a discrete amplifier design.

Features

- Available in 37 dB and 39 dB versions and may be configured with a single-pilot ALSG to maintain forward levels as temperature changes cable attenuation
- Various pilot frequencies are available, including 427.25 MHz and 499.25 MHz
- Operates while continuously passing 15 A and can pass 25 A for up to 2 hours
- Field-accessible plug-in equalizers and attenuators, installed during system setup, come with plastic covers that protect their components and help guide them easily into place
- Directional coupler output testpoint isolates forward output signal from the effects of reflections in the cable
- On the return output, an attenuator and an equalizer circuit controlled by a plug-in attenuator allow for accurate return path alignment (return test signals can be injected at the forward output testpoint)
- A crowbar plug-in circuit offers additional surge protection
- Easy conversion from manual level control to thermal level control via plug-in PAD

Functional Block Diagram

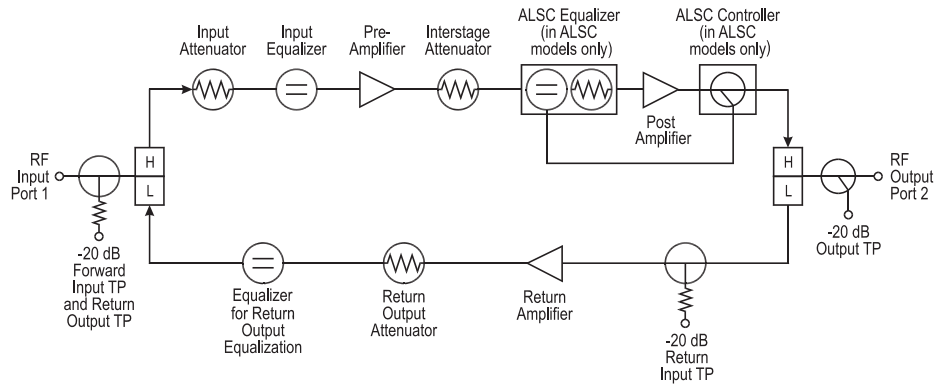

Application

Flex Max320s amplify and control forward feeder signals from a network amplifier or other line extender. Return path circuitry on the Flex Max320's PC board also amplifies return signals from the subscriber.

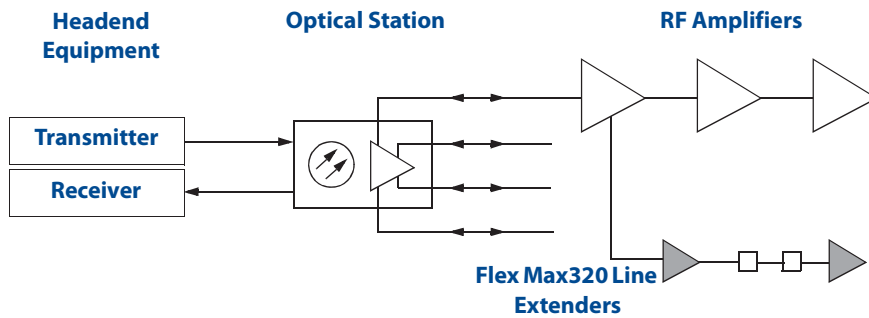

Application Diagram

Specifications

	Forward			Return
General				
Bandwidth, MHz	54 to 870			5 to 42
AC Current Passing, A	15			15
Typical Operating Conditions	Manual	Thermal	ALSC	
Operational Gain, dB (Note 1)				
7-MMLE198/37	37	34	30	20
7-MMLE198/39	39	36	32	20
Performance Specifications				
79 NTSC Channels				
Composite Triple Beat, -dBc	76	74	72	84
Cross Modulation, -dBc	72	70	67	75
Composite Second Order, -dBc	73	71	70	88
96 NTSC Channels				
Composite Triple Beat, -dBc	72	70	67	84
Cross Modulation, -dBc	68	67	64	75
Composite Second Order, -dBc	64	63	61	88
112 NTSC Channels				
Composite Triple Beat, -dBc	66	64	62	84
Cross Modulation, -dBc	65	63	61	75
Composite Second Order (Fc=0.75 and 1.25MHz), -dBc	56	54	53	88
Operating Levels (recommended)				
Frequency, MHz	54/550/650/750/870			42
Output, dBmV	35.5/43.1/44.6/46.2/48.0			35
Noise Figure (54MHz/870MHz, add 1 dB for equalizer), dB	7.5/8.5			7.5
Response Flatness manual option, dB (Note 2)	±0.8			±0.9
Return Loss (excluding guard bands) dB (Note 3)	16			16
Testpoints (forward and return), dB	-20			-20
Internal Tilt, dB	8			
Powering Specifications				
Hum Modulation @ 15A				
5 to 12MHz, dBc				-55
12 to 42MHz, dBc				-65
54 to 870MHz, dBc				-65
AC Power Consumption				
Manual mode, W				23
ALSC mode, W				24.5
Physical and Environmental Specifications				
Module Dimensions—excluding housing (W x H x D), cm	17.12 x 10.41 x 8.52 (6.74 x 4.10 x 3.35 in.)			
Operating Ambient Temperature, °C	-40 to 60 (-40 to 140°F)			

Notes:

- Spacing is at the highest frequency and includes 1 dB loss for equalizer.
- The uppermost 2MHz of the return band may exceed this specification and roll off up to 0.75dB.
- Return loss for all 75 Ohm ports from 5MHz to 7MHz may be as low as 13dB.
- Specifications are for typical performance at 25°C (unless otherwise noted).

Specifications are subject to change without notice.

